

# ISL59603-Coax-EVZ/ISL59960-Coax-EVZ Evaluation Board

## Description

The ISL59603-Coax-EVZ/ISL59960-Coax-EVZ is a standalone board designed for evaluation of the ISL5960x (MegaQ™) and ISL59960 (960MegaQ™) parts without digital programming. It also provides the reference schematic and PCB layout of a typical MegaQ™/960MegaQ™ coaxial application. This reference schematic is easy to implement and is only needed at the receive side of the transmission path. For the ISL59605IRZ-EVALZ evaluation board, see [AN1598](#).

## Power Connection and PCB Layout

The power connector is at the top left of the evaluation board. The board requires a +12V DC power supply capable of supplying at least 100mA.

The board uses the ISL8500 DC/DC buck converter to generate the +5V supply for the chip. MegaQ™/960MegaQ™ employs up to 70dB of high frequency gain to equalize long lengths of cable; therefore, the ground for the ISL8500 is isolated from the ground of the MegaQ™/960MegaQ™ except at the bypass capacitor (C7). This is done to prevent the switching noise from coupling into the MegaQ™/960MegaQ™ ground and corrupting the output signal when utilizing high equalization.

The PCB was laid out so that the feedback path from the +5V output back to pins 1 and 2 on the ISL8500 does not cross any of the high current switching components (L1 and D1). For more details on the power supply layout, see Figures 3-6.

## Input Connection

Coax signals are connected through the “VIDEO IN” BNC connector on the left side of the board.

## Output Connection

Standard 75Ω composite video is available at the “VIDEO OUT” BNC connector on the right side of the board.

## Switch Settings

The DIP switch (SW1) is used to put MegaQ™/960MegaQ™ in its different operational modes (recommended settings are underlined>):

- **Continuous/Lock until Reset:** When set to “Continuous”, MegaQ™ will continuously update the EQ settings. When set to “Lock until Reset”, the FREEZE input is connected to the LOCKED output so that the device will stop updating once the first optimum solution is reached. “Lock until Reset” is the recommended mode of operation. See the [datasheet](#) for more detailed information on the locking modes.
- **COLOR-AUTO/COLOR-MAN:** Determines whether the COLOR pin is floating (“Auto”) or set by the “COLOR-0/COLOR-1” switch (“Man”). When set to “Auto”, MegaQ™/960MegaQ™ will automatically determine if the incoming signal is color or monochrome. If set to “Man” (manual) the polarity of the COLOR pin is determined by the “COLOR-0/COLOR-1” switch.

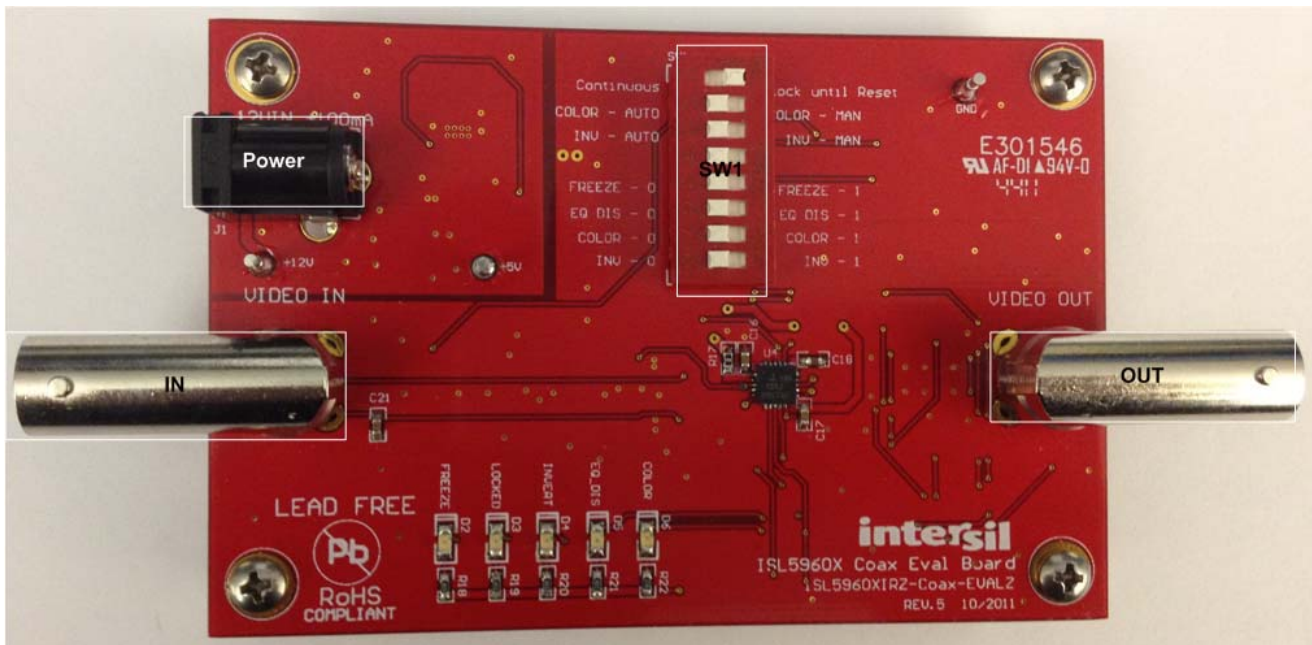

FIGURE 1. TOP VIEW OF EVALUATION BOARD

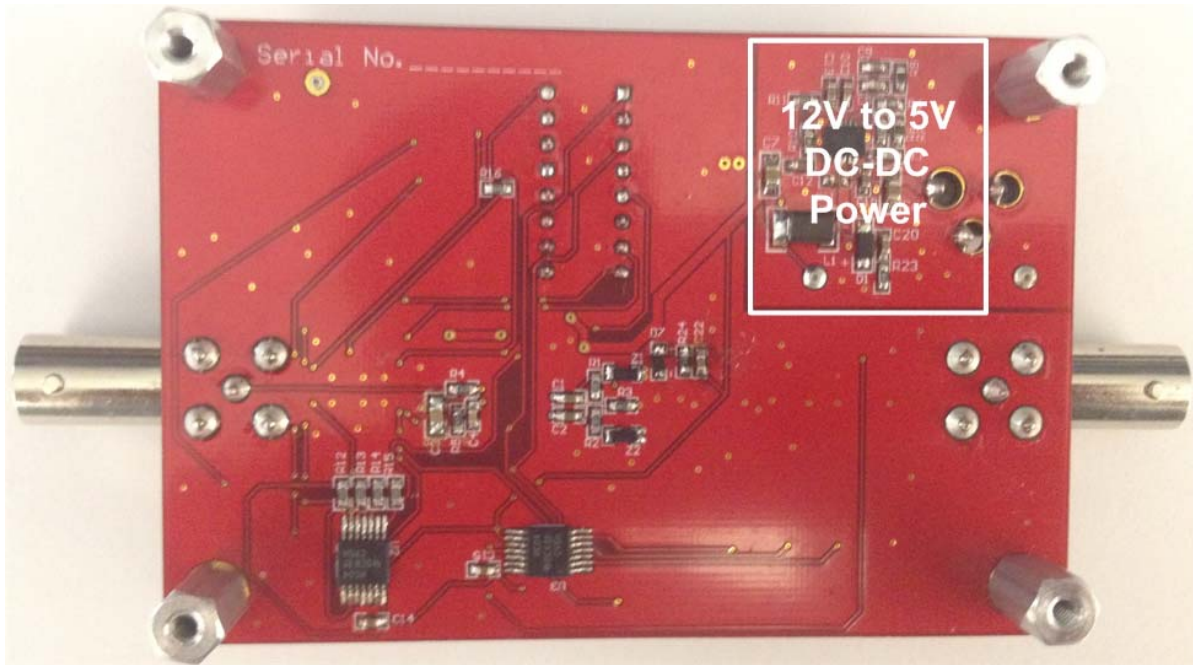

FIGURE 2. BOTTOM VIEW OF EVALUATION BOARD

- **INV-AUTO/INV-MAN:** Determines whether the INVERT pin is floating (“Auto”) or set by the “INV-0/INV-1” switch (“Man”). When set to “Auto”, MegaQ™/960MegaQ™ will automatically determine the polarity of the incoming signal. If set to “Man” (manual), the polarity of the INVERT pin is determined by the “INV-0/INV-1” switch.
- **FREEZE-0/FREEZE-1:** Slide the switch left to the “0” position to put the part in Continuous Update mode. The “1” position freezes the equalizer in its current state. This switch is ignored when the “Continuous/Lock until Reset” switch is set to “Lock until Reset”. See the [datasheet](#) for more detailed information on the locking modes.
- **EQ DIS-0/EQ DIS-1:** This can be used to disable the EQ so that an external source can drive a signal over the cable. This switch should be set to the “0” position for normal operation.
- **COLOR-0/COLOR-1:** Slide the switch left to the “0” position to force monochrome (sync tip) equalization mode. Slide the switch right to the “1” position to force color-burst equalization mode. This switch is ignored when the “COLOR-AUTO/COLOR-MAN” switch is set to the “Auto” position.
- **INV-0/INV-1:** Slide the switch left to the “0” position for nominal input signal polarity (positive signal on IN+ and negative signal on IN-). Slide the switch right to “1” position for inverted polarity (positive signal on IN- and negative signal on IN+). This switch is ignored when the “INV-AUTO/INV-MAN” switch is set to the “Auto” position.

## LEDs

There are 5 LEDs at the bottom right of the board that indicate the current state of the EQ\_DIS, COLOR, INVERT, LOCKED, and FREEZE signals. When any LED is illuminated then the corresponding signal is a logic high. When the LEDs are illuminated, they will draw additional supply current from the 5V supply.

## Related Documents

- ISL5960x Datasheet ([FN6739](#))
- ISL59960 Datasheet ([FN8358](#))
- ISL59605-SPI-EVALZ/ISL59960-SPI-EVALZ Evaluation Board (with Serial Interface) Operation (Rev 5.0) ([AN1775](#))
- ISL59605-Catx-EVZ/ISL59960-Catx-EVZ Evaluation Board ([AN1780](#))

## Troubleshooting

1. Make sure all the switches are in the correct position for the intended operation.
2. Verify that there is +12V at the “12V” test point and +5V at the “5V” test point. Check that the “EQ DIS” switch is set to “0”.
3. You should see a signal on IN+ and a DC voltage on IN-. If you do not see the expected signals, inspect your cables, video sources, etc.
4. If you see the correct input signal on IN+ and IN- but are still not seeing a valid output signal, set the “INV-Auto/INV-Man” to the “Auto” position or set it to the “Man” position and set the “INV-0/INV-1” switch to the “0” position.
5. Probe the VIDEO OUT BNC connector with a scope to see if there is a video signal. If you do not see a composite video signal at the output, and there is a signal present at the input, then the device may be damaged, in which case, please contact your vendor.

# ISL59603-Coax-EVZ/ISL59960-Coax-EVZ Evaluation Board Schematic

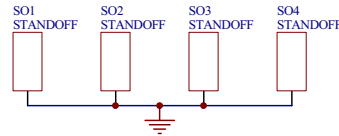
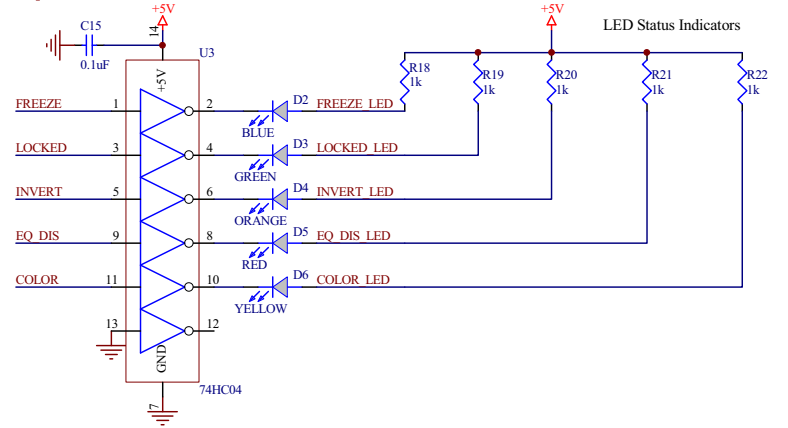
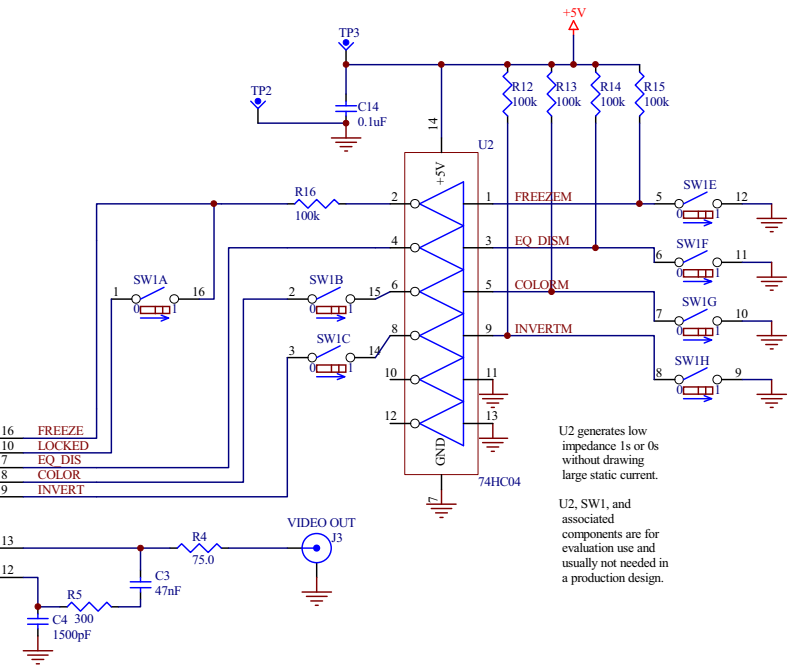
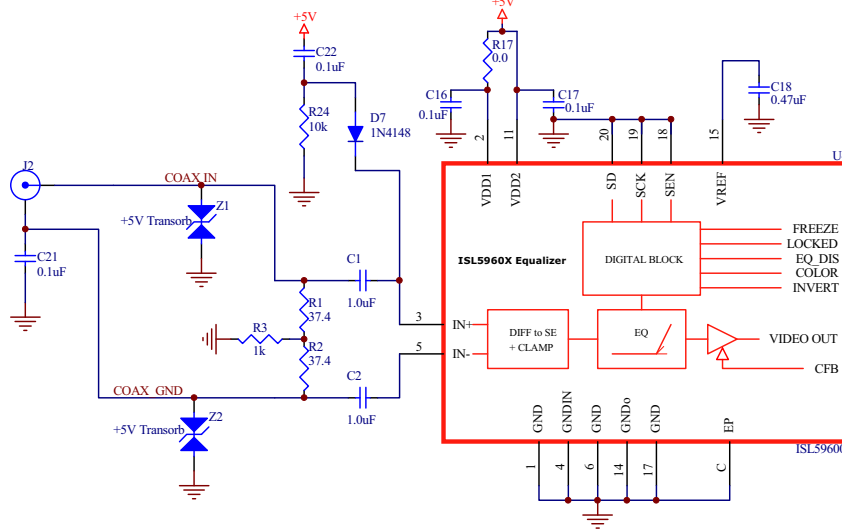
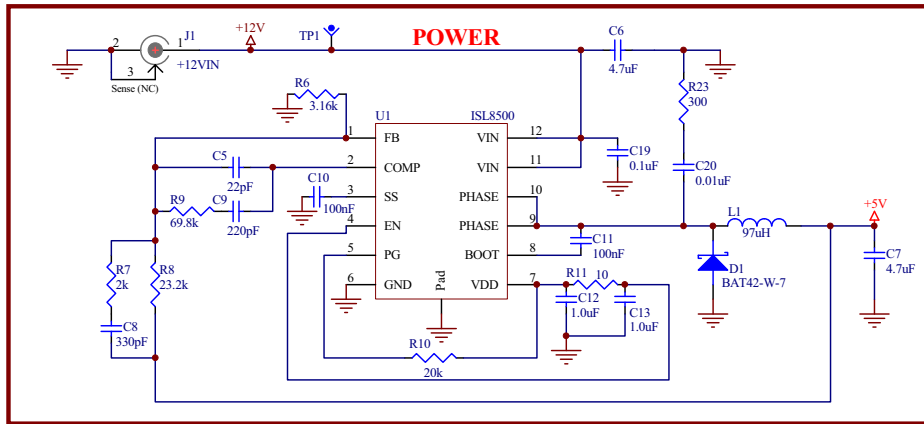

**intersil**

LEAD FREE  
RoHS COMPLIANT

# ISL59603-Coax-EVZ/ISL59960-Coax-EVZ Board Layout

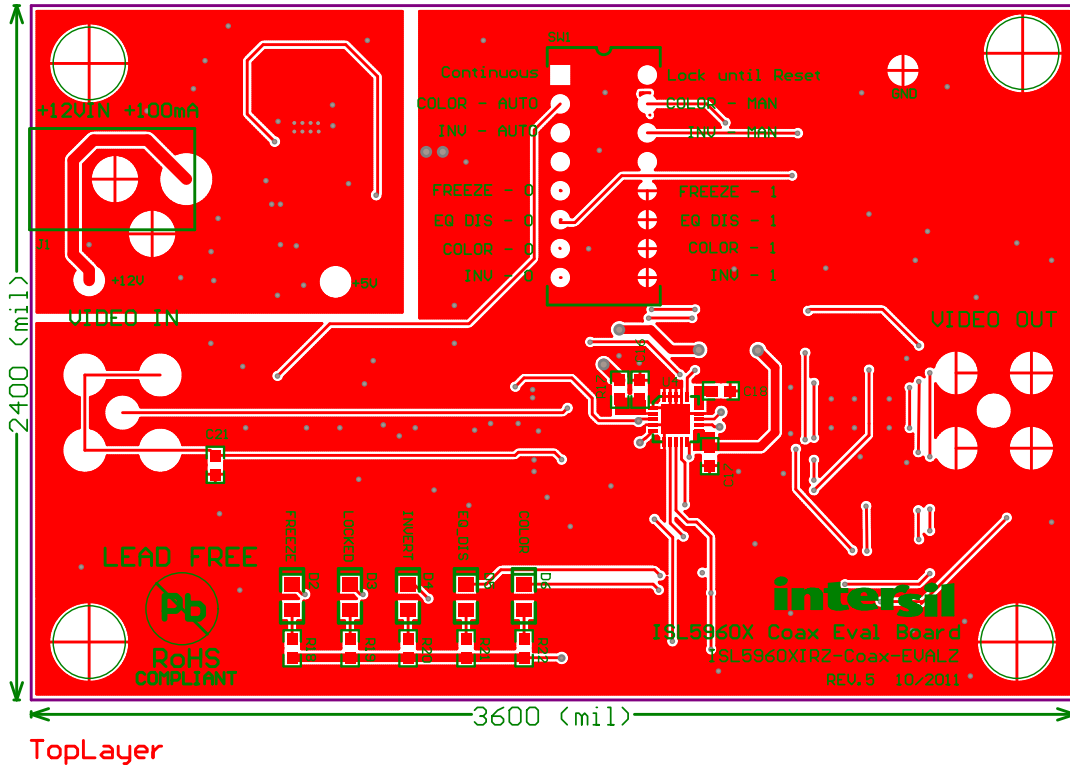

FIGURE 3. PCB TOP LAYER WITH SILKSCREEN

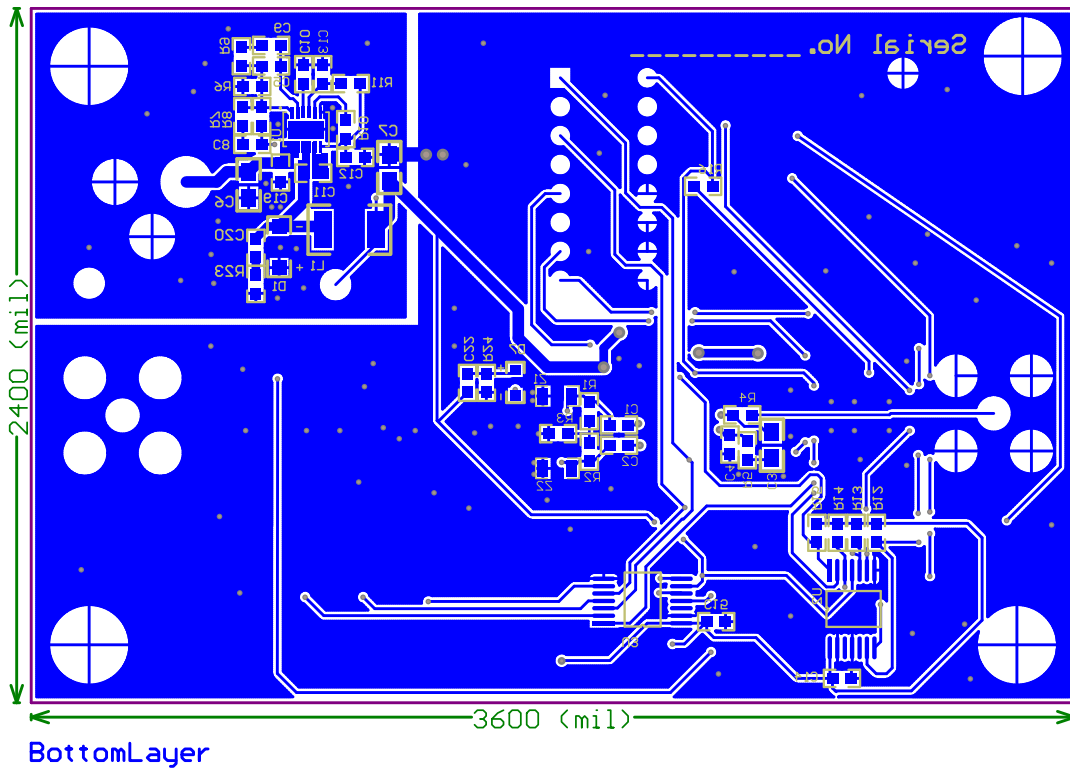

FIGURE 4. PCB BOTTOM LAYER WITH SILKSCREEN

ISL59603-Coax-EVZ/ISL59960-Coax-EVZ Board Layout (Continued)

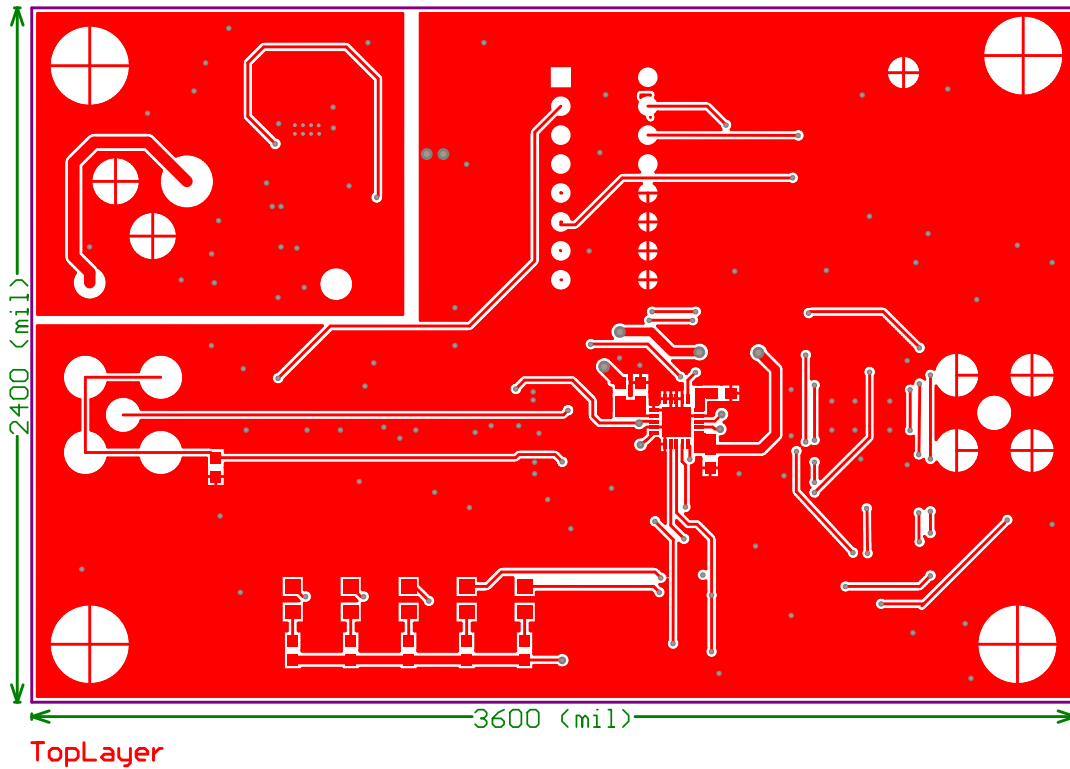

FIGURE 5. PCB TOP LAYER

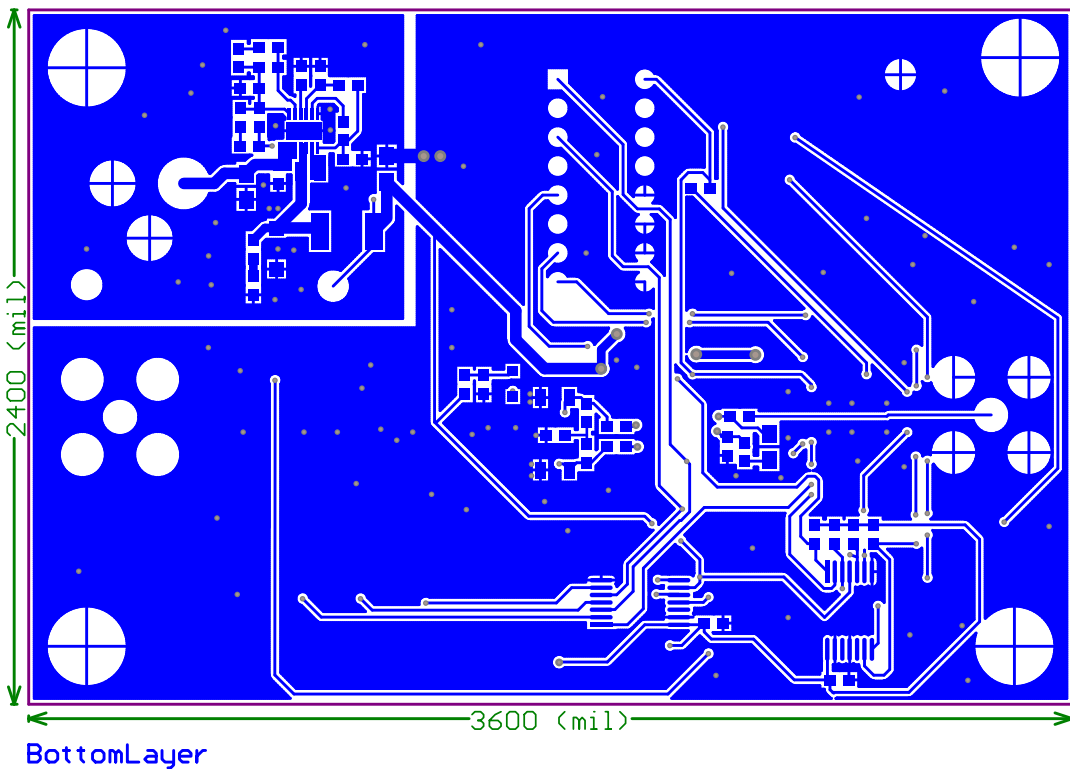

FIGURE 6. PCB BOTTOM LAYER

## Application Note 1776

### Bill of Materials

QUANTITY	COMPONENT NAME	VALUE	FOOTPRINT
1	J1	+12VIN	Power Conn
2	Z1, Z2	CPDFR5V0	1005
1	D7	1N4148	SOD-323F
1	R17	0.0	0603
1	C20	0.01 $\mu$ F	0603
6	C14, C15, C16, C17, C19, C21	0.1 $\mu$ F	0603
1	C22	0.33 $\mu$ F	0603
1	C18	0.47 $\mu$ F	0603
4	C1, C2, C12, C13	1.0 $\mu$ F	0603
1	R11	10	0603
5	R12, R13, R14, R15, R16	100k	0603
2	C10, C11	100nF	0603
1	R24	10k	0603
1	C4	1500pF	0603
6	R3, R18, R19, R20, R21, R22	1k	0603
1	R10	20k	0603
1	C9	220pF	0603
1	C5	22pF	0603
1	R8	23.2k	0603
1	R7	2k	0603
1	R6	3.16k	0603
2	R5, R23	300	0603
1	C8	330pF	0603
2	R1, R2	37.4	0603
1	R9	69.8k	0603
1	R4	75.0	0603
2	C6, C7	4.7 $\mu$ F	0805
1	C3	47nF	0805
1	L1	97 $\mu$ H	1812
2	U2, U3	74HC04	TSSOP-14
1	U4	ISL59600	QFN20 4MM
1	U1	ISL8500	DFN12 4X3MM
1	D1	BAT42-W-7	SOD-123
1	D2	BLUE	LED-0805
1	D4	ORANGE	LED-0805
1	D5	RED	LED-0805
1	D6	YELLOW	LED-0805
1	D3	GREEN	LED-0805
1	J2	BNC	BNC-EDGE
1	J3	VIDEO OUT	BNC-EDGE
1	SW1	SWITCH-DIP16	SWITCH-DIP8X2

Intersil Corporation reserves the right to make changes in circuit design, software and/or specifications at any time without notice. Accordingly, the reader is cautioned to verify that the Application Note or Technical Brief is current before proceeding.

For information regarding Intersil Corporation and its products, see [www.intersil.com](http://www.intersil.com)